

UNIT PLAN FOR SUBPLOT NO: 4-5-6-7

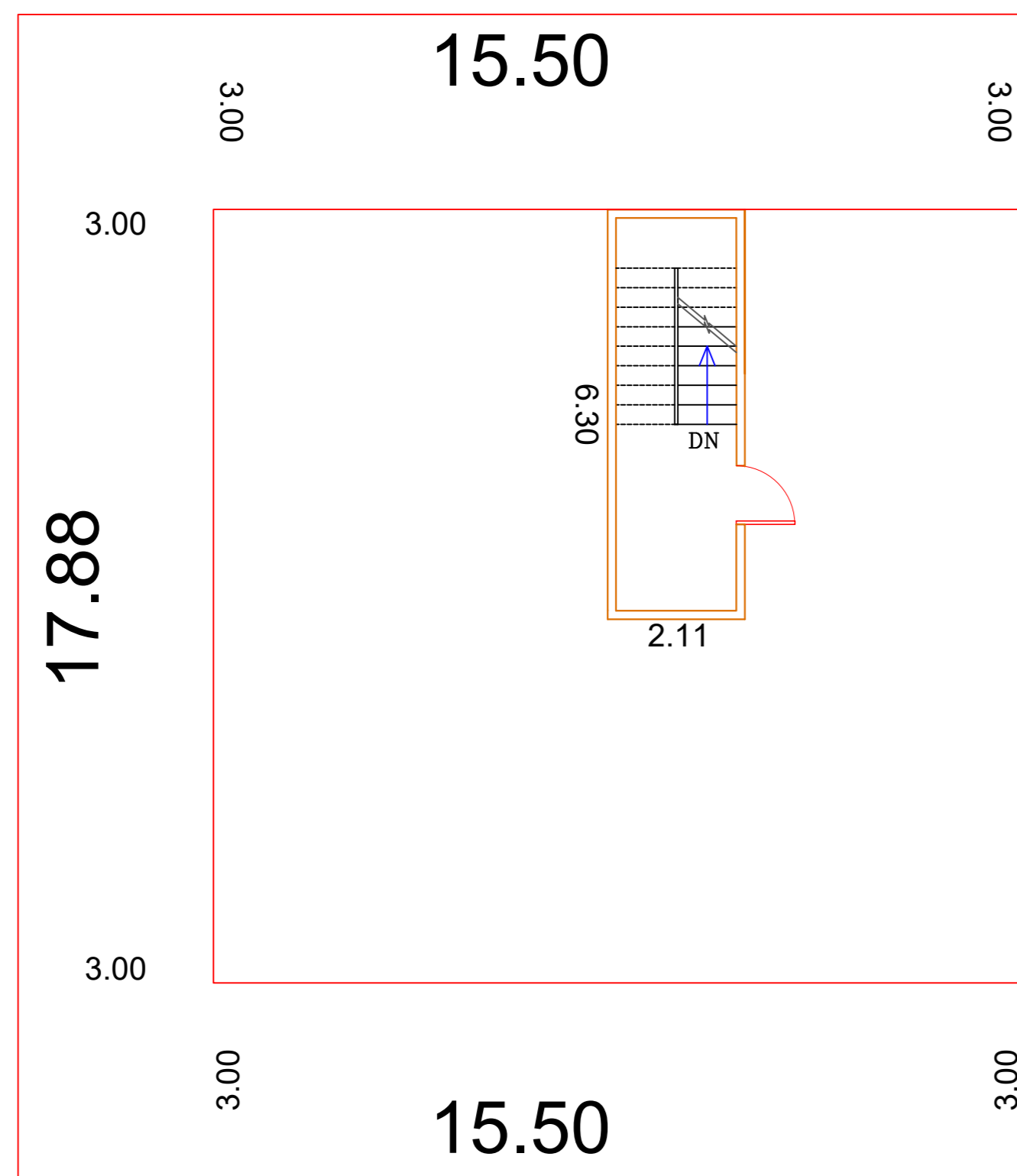

TERRACE FLOOR

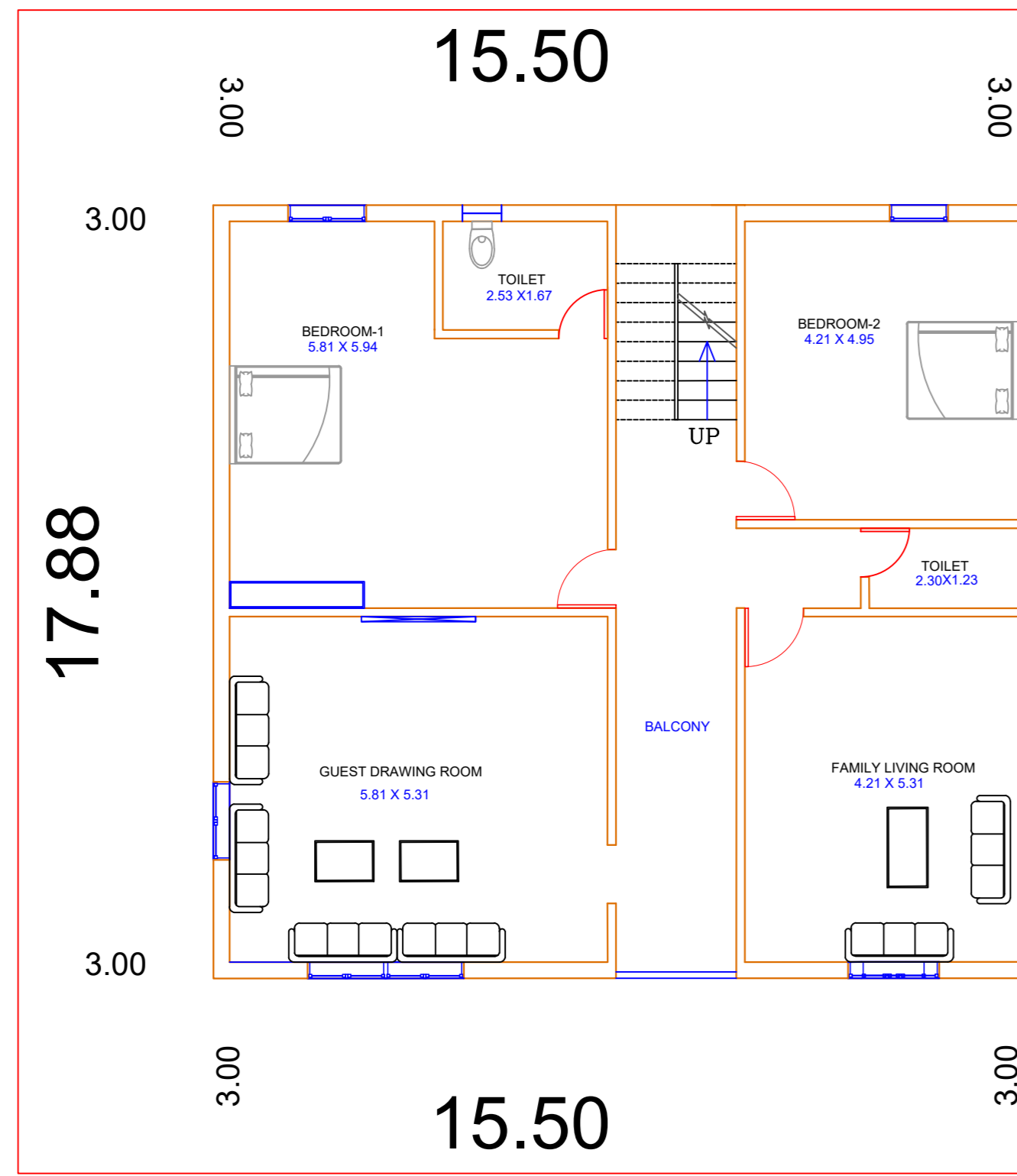

FIRST FLOOR

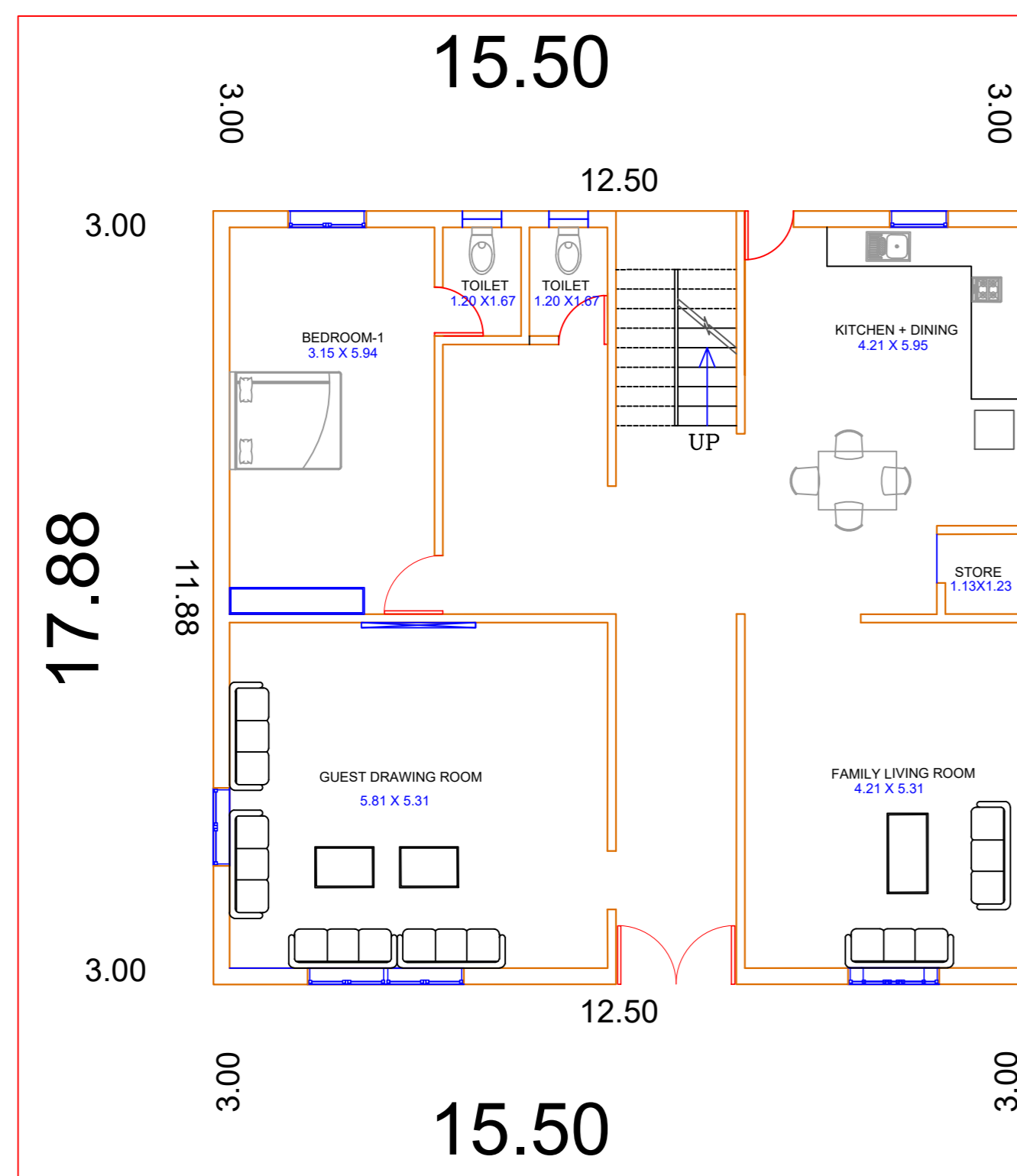

GROUND FLOOR
(UNIT AREA- 277.14 SQMT)

UNIT PLAN FOR SUBPLOT NO: 1-2-9-10

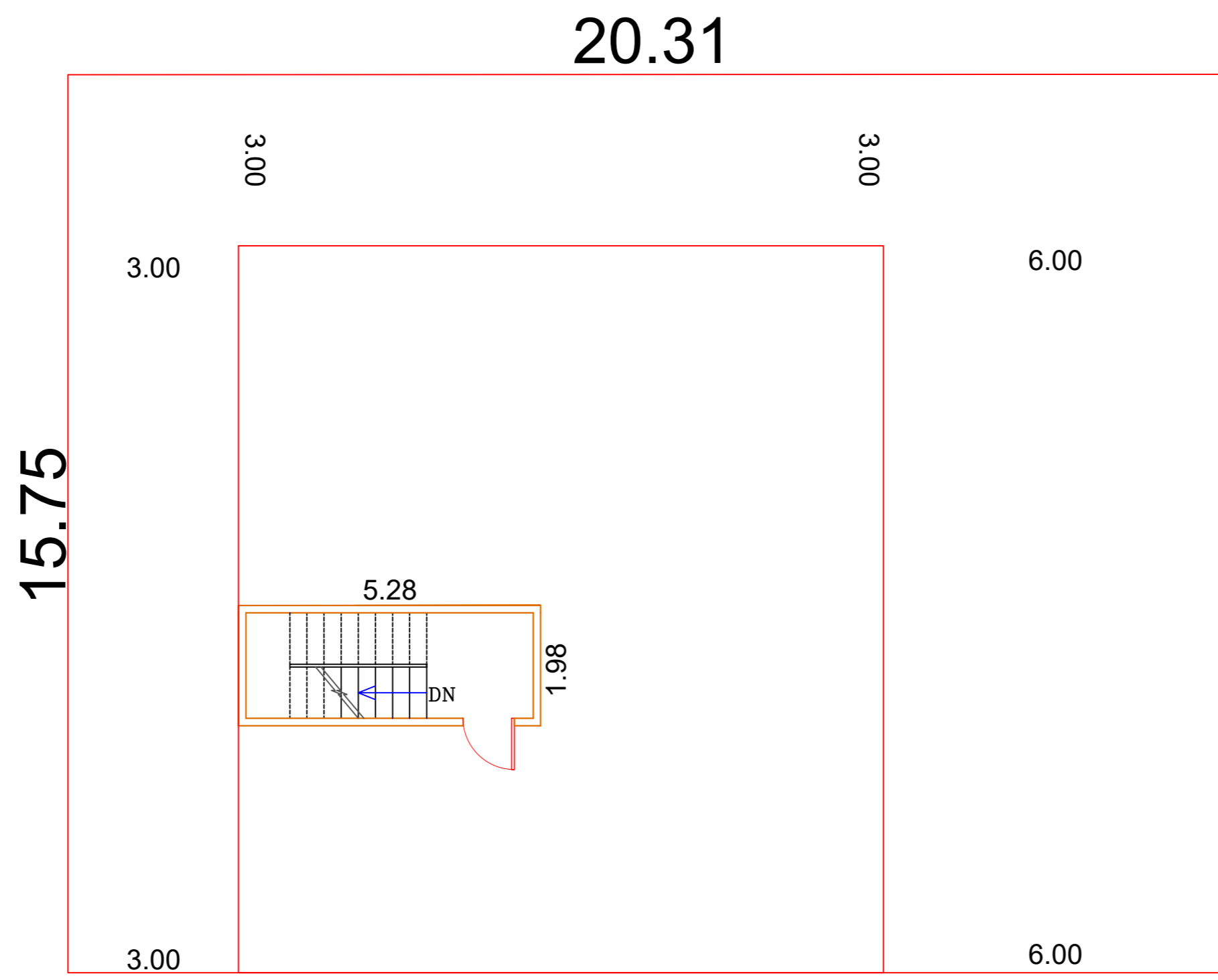

TERRACE FLOOR

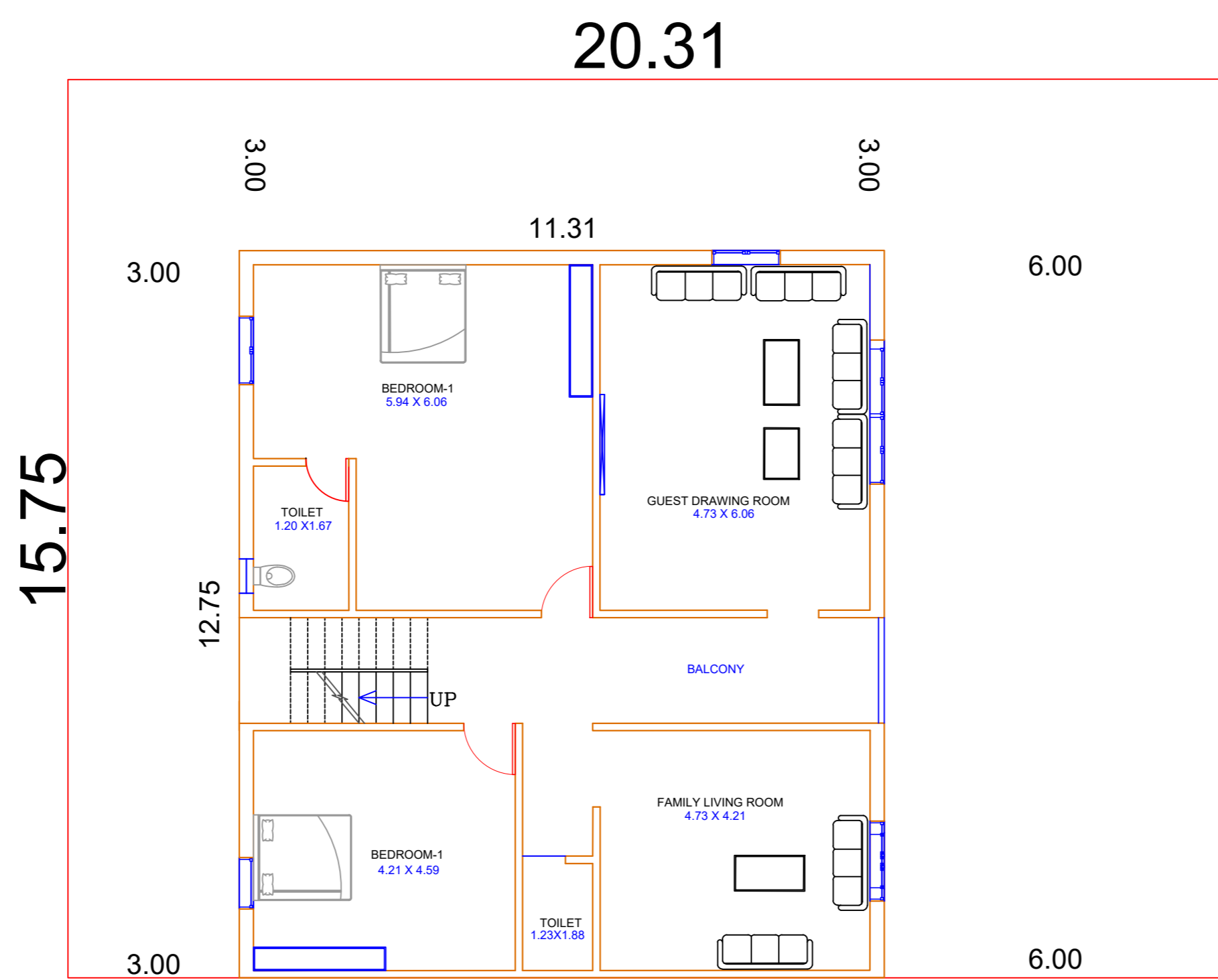

FIRST FLOOR

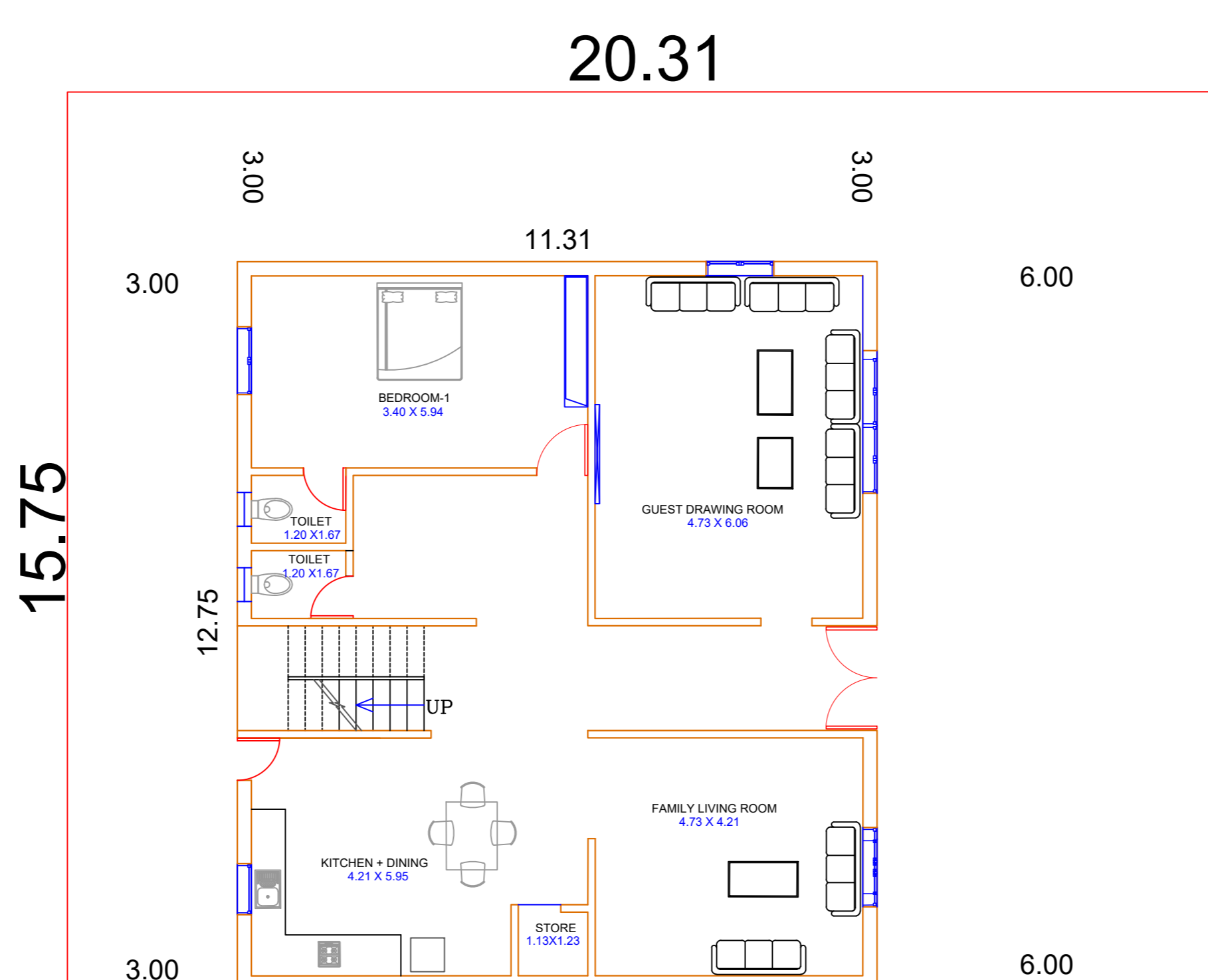

GROUND FLOOR
(UNIT AREA- 319.88 SQMT)

UNIT PLAN FOR SUBPLOT NO: 3-8

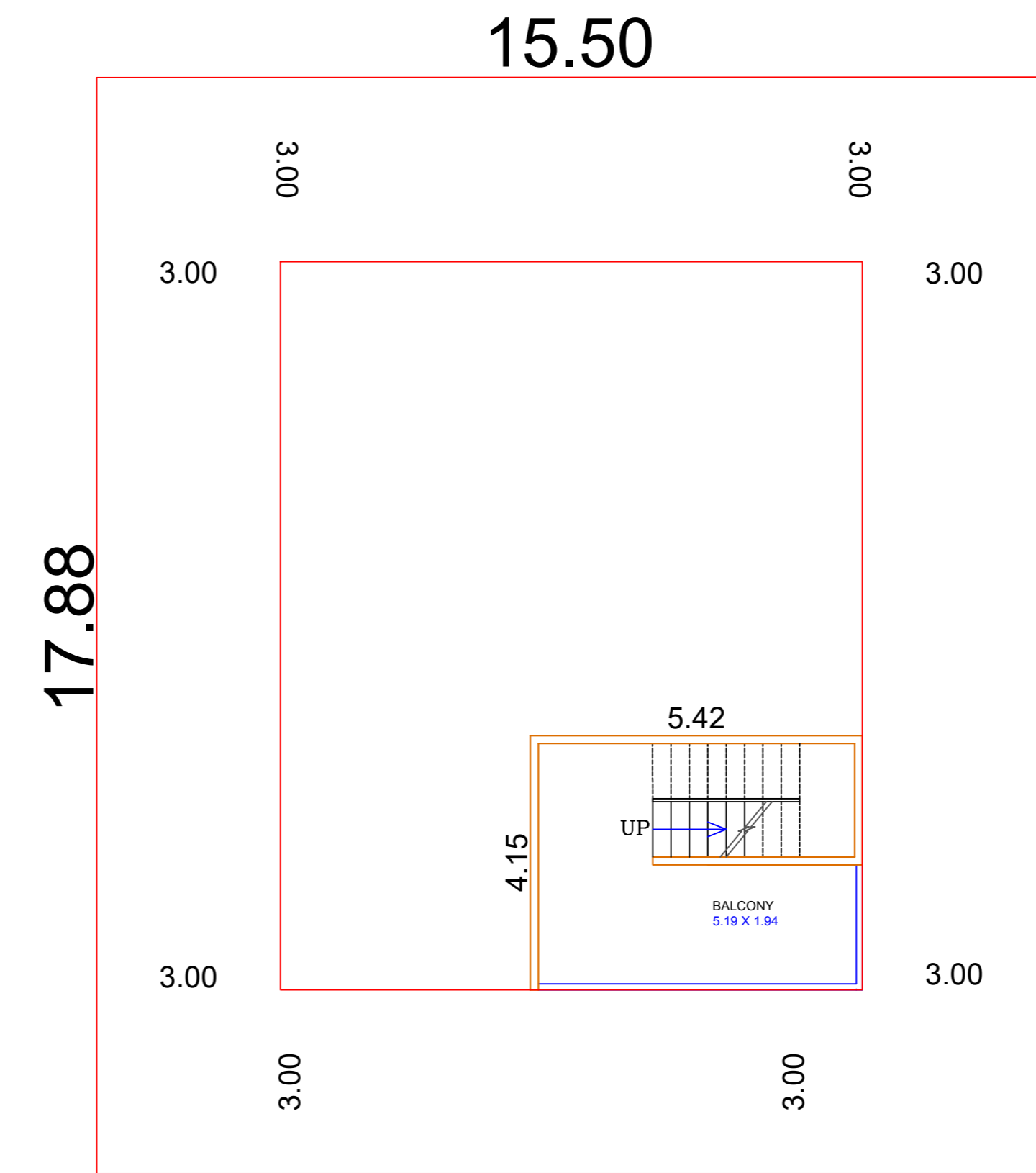

FIRST FLOOR

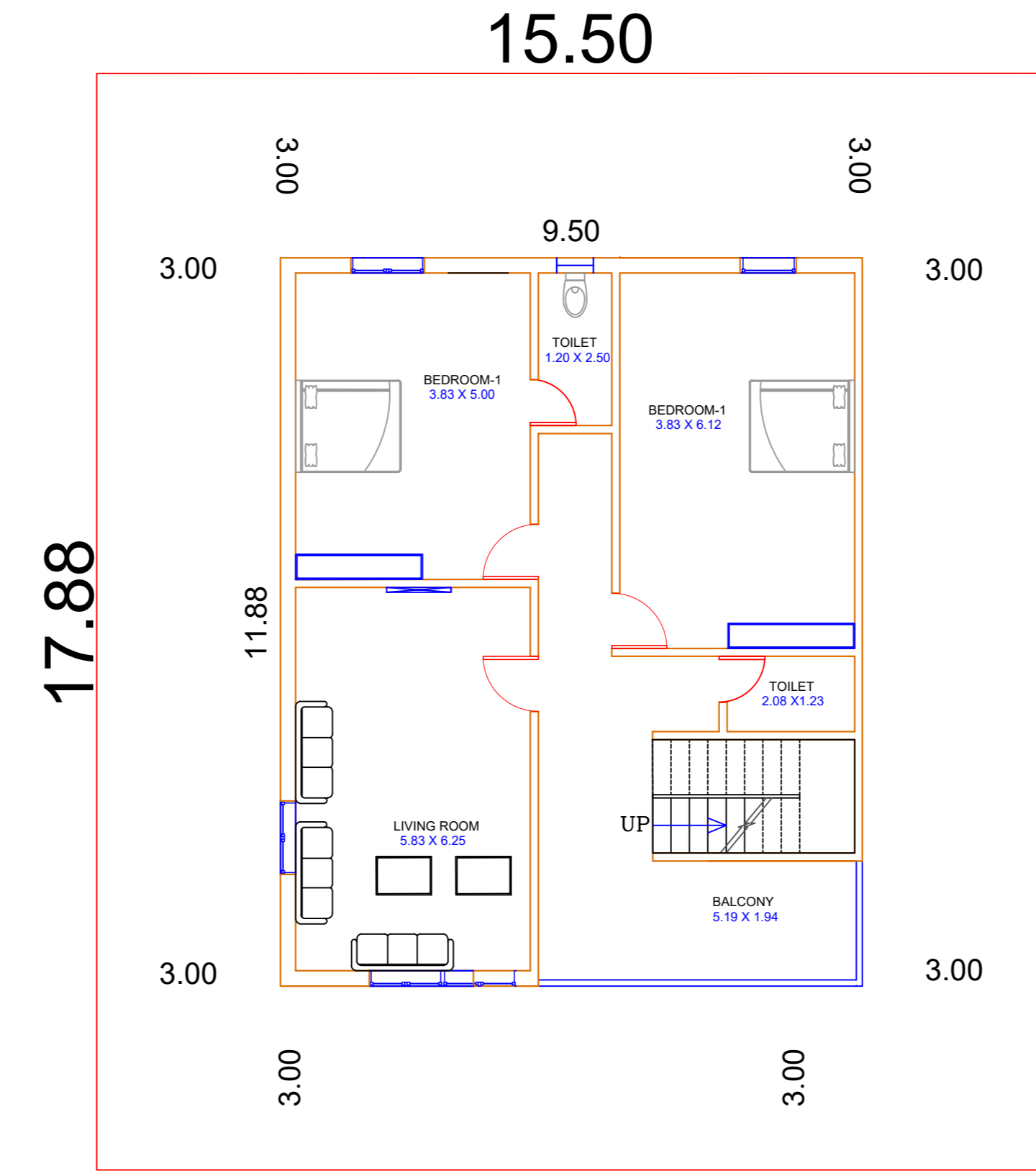

FIRST FLOOR

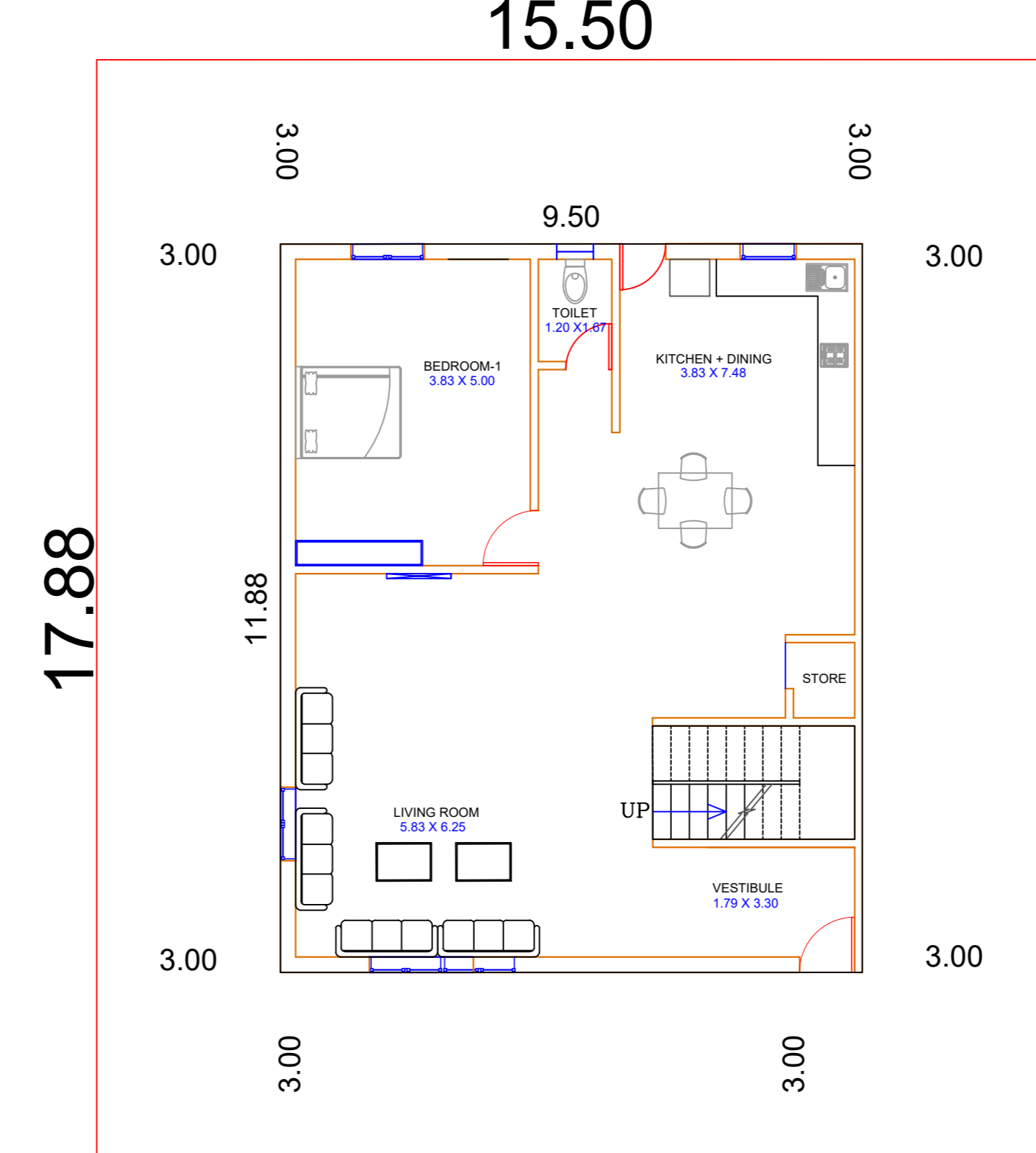

GROUND FLOOR
(UNIT AREA- 277.14 SQMT)

**UNIT PLAN:
SCALE: NTS**

LAYOUT SHOWING PROPOSED OPEN SUBPLOTING FOR SURVEY NUMBER 260, VILLAGE BAVLIYARI, TA. DHOLERA, DIST. AHMEDABAD TP SCHEME NO. 5B OF DSIRDA OP No. 84/2 FP No. 84/2

ZONE: RESIDENTIAL

AREA TABLE

DISCRIPTION	AREA IN SQ.MT.
PROPOSED GROUND COVERAGE	148.50
PERMISSIBLE F.S.I @1	277.14
PROPOSED F.S.I	274.01
PROPOSED BUILT-UP (SQMT)	161.79
PROPOSED BUILT-UP (SQFT)	1741.50 (SQFT)

DISCRIPTION	AREA IN SQ.MT.
PROPOSED GROUND COVERAGE	144.20
PERMISSIBLE F.S.I @1	319.88
PROPOSED F.S.I	263.14
PROPOSED BUILT-UP (SQMT)	298.85
PROPOSED BUILT-UP (SQFT)	3216.80 (SQFT)

DISCRIPTION	AREA IN SQ.MT.
PROPOSED GROUND COVERAGE	112.86
PERMISSIBLE F.S.I @1	277.14
PROPOSED F.S.I	217.14
PROPOSED BUILT-UP (SQMT)	248.21
PROPOSED BUILT-UP (SQFT)	2671.71 (SQFT)